

Code:

ASC10

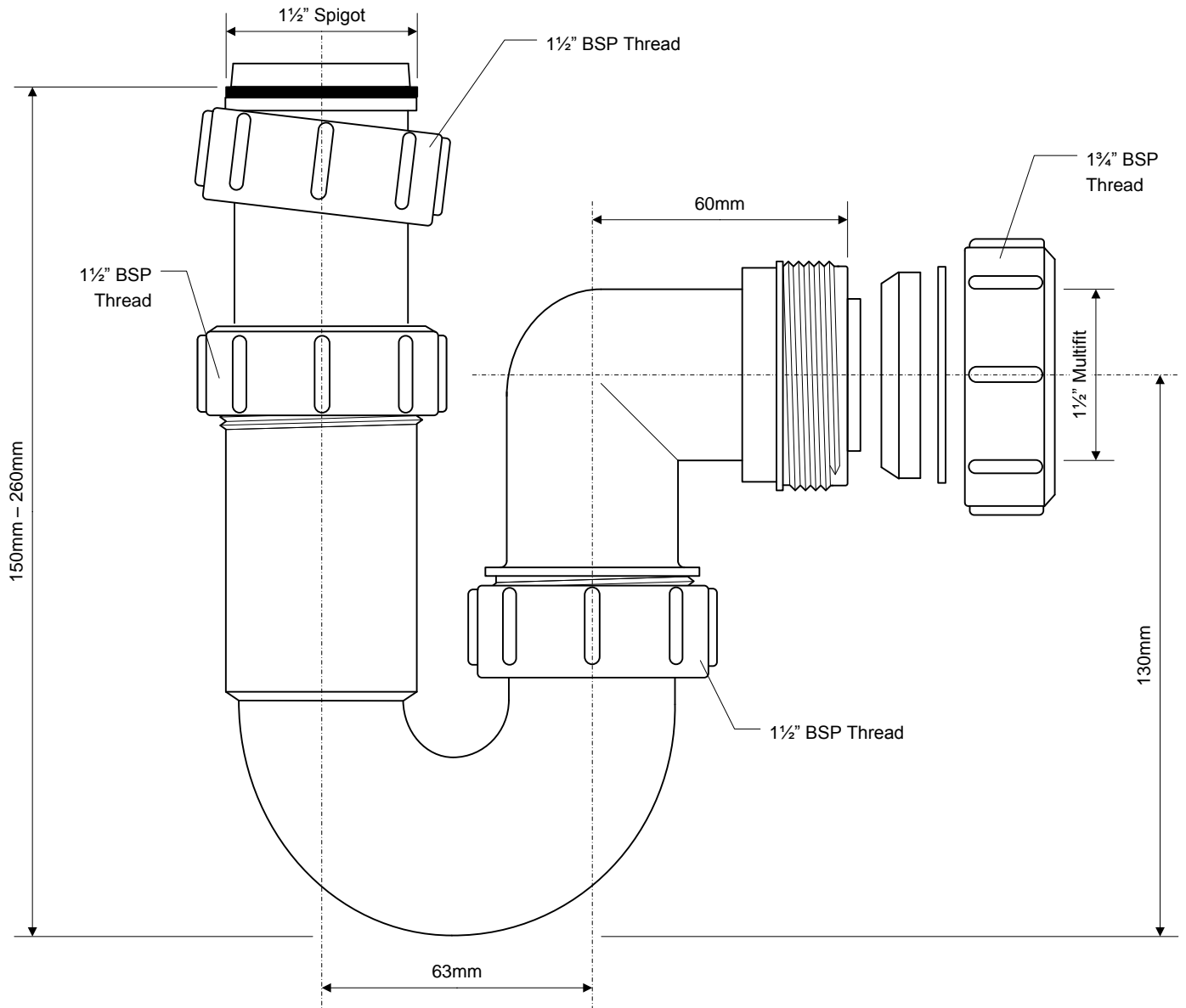

McALPINE

Drawing verified  
correct as of:

09.06.16  
T.C.

DRAWN BY

TC

SCALE

1: 1.5

REVISED

1 - Re-drawn to scale  
(TC 09.06.16)

FILENAME

ASC10.VSD

DATE

09.06.16

Code:

ASC10

No.	Qty	Code	Material
1	2	RW2	Nitrile
2	2	T8A	Polypropylene
3	1	STALK-1.5-ORD	Polypropylene
4	1	T8B	Polypropylene
5	1	T13-ISON	TPE
6	1	1.5-ADJ	Polypropylene
7	1	SC10OUTLETBODY	Polypropylene
8	1	RWM2	Nitrile
9	1	PWM2	Polypropylene
10	1	T8M	Polypropylene

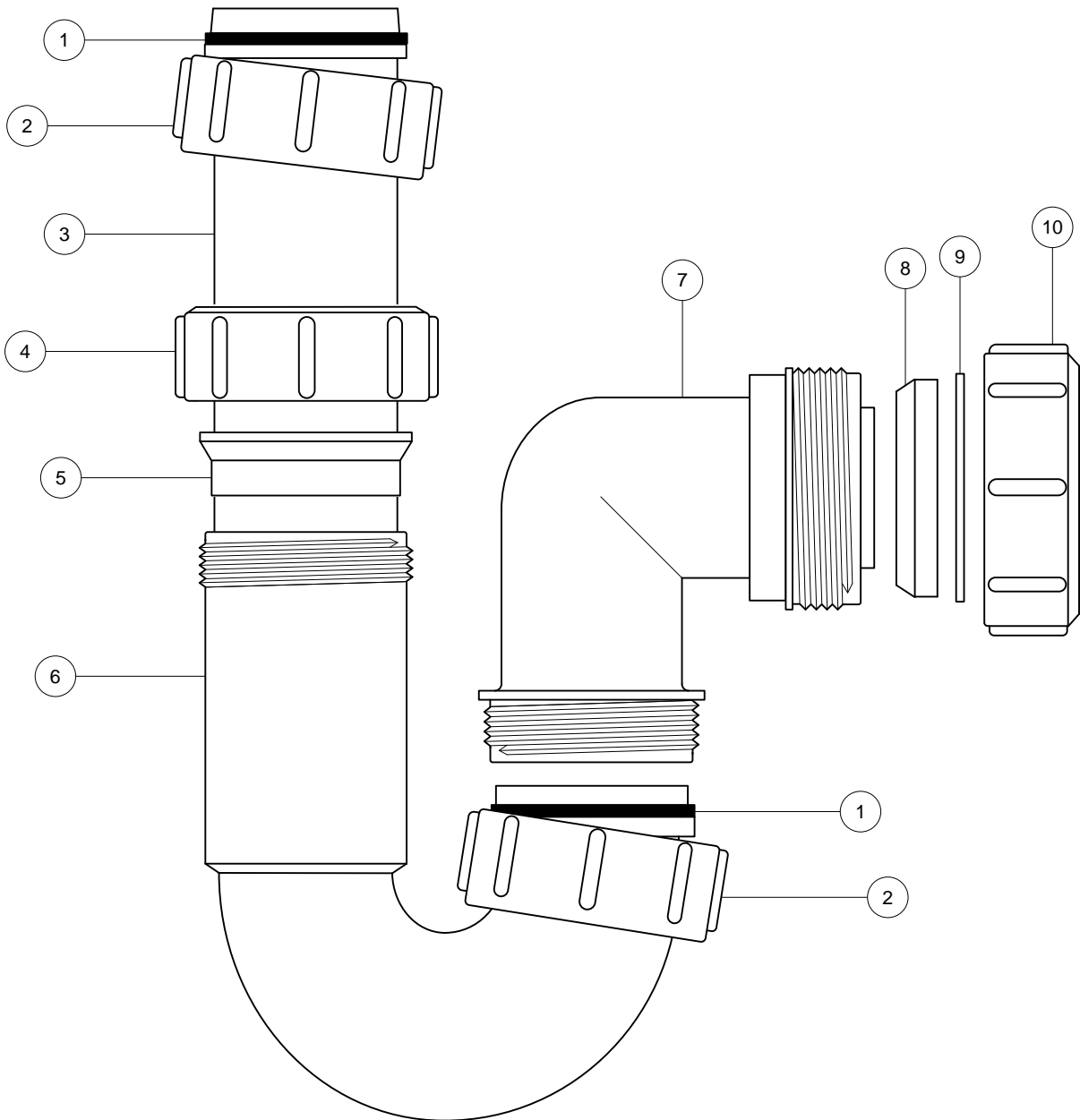

©

McALPINE

Drawing verified  
correct as of:

09.06.16  
T.C.

DRAWN BY

TC

SCALE

1: 1.5

REVISED

1 - Re-drawn to scale  
(TC 09.06.16)

FILENAME

ASC10.VSD

DATE

09.06.16